

ACOUSTIC PET PANELS

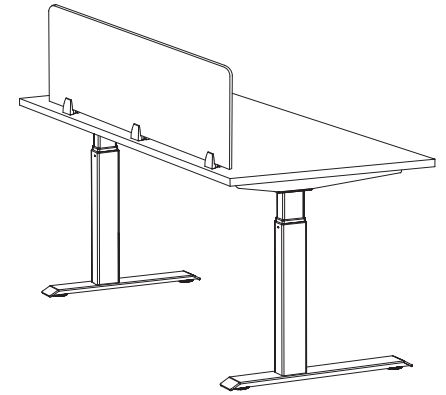

Mounted Above

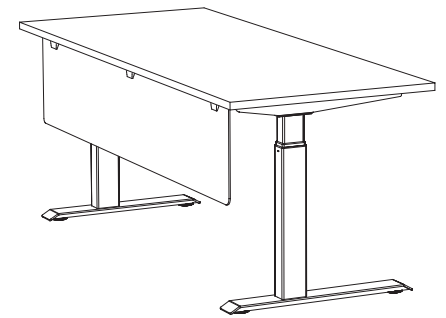

Mounted Below

- 12mm thick tackable acoustic frameless PET felt panels made from recycled eco-friendly material (100% polyester)
- A-level permanent fire protection
- Available in Charcoal Grey (CH) or Storm Grey (ST) finish
- Mountable above or below worksurfaces with brackets available in Black (BL) or Silver (SL)

Outlines *Plus*
Stylish affordability

HDL[®]
Heartwood Distributors Ltd.

Model:

OUT-TM1-1524PET
OUT-EM1-1524PET

Dimensions: 21.75"W x 0.5"D x 14.75"H

OUT-TM1-1530PET
OUT-EM1-1530PET

Dimensions: 27.75"W x 0.5"D x 14.75"H

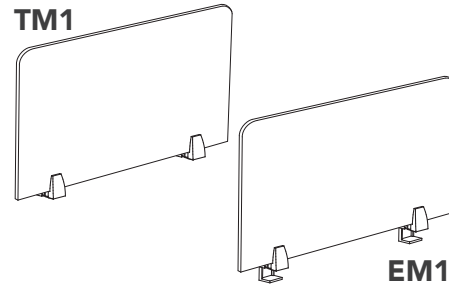

(2 brackets per panel & 1" insets from each end)

Model:

OUT-TM1-1560PET
OUT-EM1-1560PET

Dimensions: 55.25"W x 0.5"D x 14.75"H

OUT-TM1-1566PET
OUT-EM1-1566PET

Dimensions: 61.25"W x 0.5"D x 14.75"H

OUT-TM1-1572PET
OUT-EM1-1572PET

Dimensions: 67"W x 0.5"D x 14.75"H

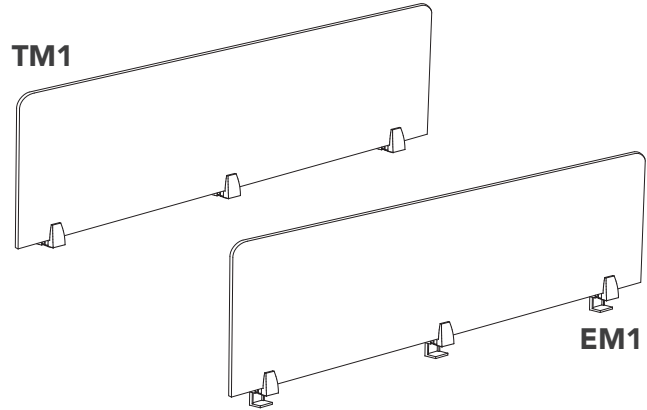

(3 brackets per panel & 2" insets from each end)

Panel Finish:

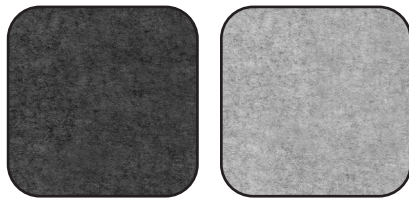

Charcoal Grey (CH) Storm Grey (ST)

Bracket Finish:

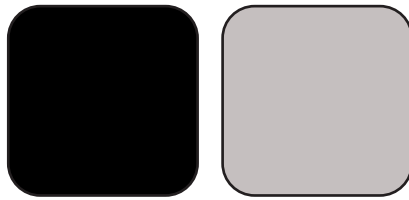

Black (BL) Silver (SL)

Details:

- Choose mounting hardware - either Top Mount (TM1) or Edge Mount (EM1) in Silver (SL) or Black (BL). Edge Mount hardware will fit 1" or 1-1/16" thick surfaces and can be removed without damaging the worksurface
- 24" and 30" wide PET panels are inset 1" on either end
- 60", 66", and 72" wide PET panels are inset 2" on either end
- Order panel width to match width of adjoining surface (ex: order an OUT-TM1/EM1-1560PET panel to fit an INV-3060DS - 60" wide desk shell)



Heartwood Distributors Ltd.

Heartwood Distributors Ltd.

Choose high quality, price sensitive products that are **IN-STOCK** and ready for next day shipping.

www.heartwooddl.com

Contact your local dealer:

251 Adams Rd, Kelowna, BC V1X 7R1

T: 1 800 567 3060

F: 250 765 1213